

Sc

KEY STAGE

3

TIER

4-7

Paper 2

First name _____

Last name _____

Class _____

Date _____

Please read this page, but do not open your booklet until your teacher tells you to start. Write your name, your class and the date in the spaces above.

Remember:

- The test is 1 hour long.
- You will need a pen, pencil, rubber and ruler. You may find a protractor and a calculator useful.
- The test starts with easier questions.
- Try to answer all of the questions.
- The number of marks available for each question is given below the mark boxes in the margin. You should not write in this margin.
- Show any rough working on this paper.
- Check your work carefully.
- Ask your teacher if you are not sure what to do.

1. When you grow from a child to an adult you go through puberty.



The body changes during puberty.

The chart below shows the ages when these changes can **start** to happen.

Age when changes can START to happen in boys during puberty

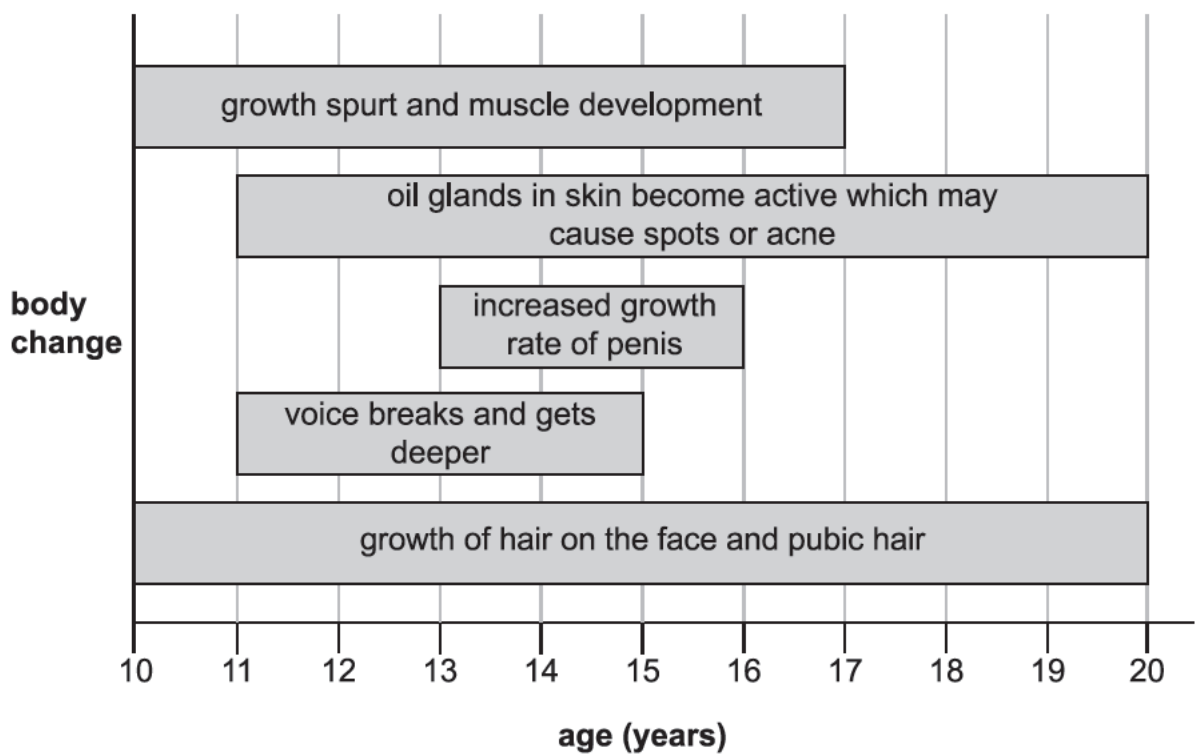

(a) Use the information in the chart to answer the following questions.

(i) What is the earliest age the voice can break and get deeper?

_____ years

ai
1 mark

(ii) Which change can happen at the youngest age?

aii
1 mark

(iii) Why are teenagers more likely to get spots or acne than children?

aiii
1 mark

(iv) What evidence in the chart shows that puberty continues **after** the age of 16?

aiv
1 mark

(b) Elle says, 'Puberty starts in all boys when they are 12 years old.'
Does the evidence in the chart support Elle's statement?
Tick **one** box.

yes no

Use an example from the chart to explain your answer.

b
1 mark

maximum 5 marks

2. This photograph shows some metal water pipes. The pipes carry drinking water around buildings.



- (a) Why is metal used to make water pipes?
Tick the **three** correct boxes.

It is strong.

It can be bent
into shape.

It is magnetic.

It is shiny.

It conducts
electricity.

It is waterproof.

- (b) Some old water pipes are made from iron. When iron reacts with water and oxygen, it turns brown and flaky.

- (i) Name the process when iron reacts with water and oxygen and turns brown.

- (ii) Why should a water pipe be replaced after it has turned brown and flaky?

a

1 mark

a

1 mark

bi

1 mark

bii

1 mark

(c) The diagram below shows the temperature of hot water flowing through a metal pipe.

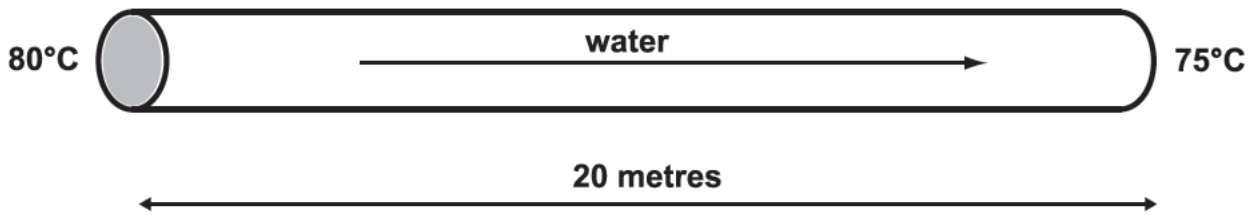

Why does the water cool down as it moves through the metal pipe?

c
1 mark

maximum 5 marks

3. Maia reads this in a book:



Hydrangeas are plants.
When they grow in acidic soil they have blue flowers.
When they grow in alkaline soil they have pink flowers.

She decides to do an investigation to see if the book is right.

Here are some of the steps in her investigation.
They are **not** in the correct order.

A
Plant a 50 cm tall hydrangea in each pot of soil.

B
Take two identical flower pots.

C
Give each plant 500 cm³ of water.

D
Stand the plants in a sunny spot in the garden.

E
Fill one pot with acidic soil and the other pot with alkaline soil.

- (a) Write the letters **A**, **C**, **D** and **E** in the boxes to show the correct order of the steps in her investigation.
The first one has been done for you.

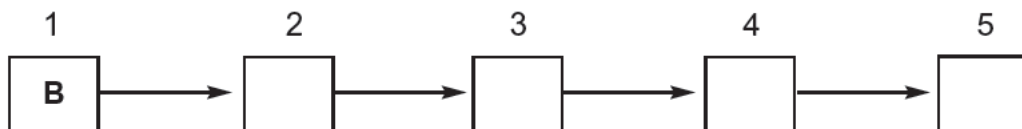

a
1 mark

- (b) Maia used 500 cm³ of water for each plant.
Give **two other** things that Maia did to make her investigation fair.

1. _____
2. _____

b
1 mark

b
1 mark

(c) (i) The table shows Maia's results.

soil type	colour of flower
acidic	blue
alkaline	pink

What did Maia use to check whether her garden soil is acidic or alkaline?
Tick the correct box.

salt water fertiliser
vinegar indicator

c
1 mark

(ii) In November Maia decides to take both plants out of the pots and put them in soil in her garden.

Maia's garden soil has a pH of 5.5.

acid						neutral	alkali							
1	2	3	4	5	6	7	8	9	10	11	12	13	14	

Predict what colour flowers Maia will see on both plants next year.
Tick the correct box.

pink blue

Explain your answer.

cii
1 mark

(iii) Maia wants to grow sunflowers next to the hydrangea plants. Sunflowers grow best when the soil pH is 6.0–7.0.
Suggest what Maia can add to her soil to change the pH so that she can grow the best sunflowers.

ciii
1 mark

maximum 6 marks

4. (a) The diagram below shows a lifeboat moving down a ramp into the sea.

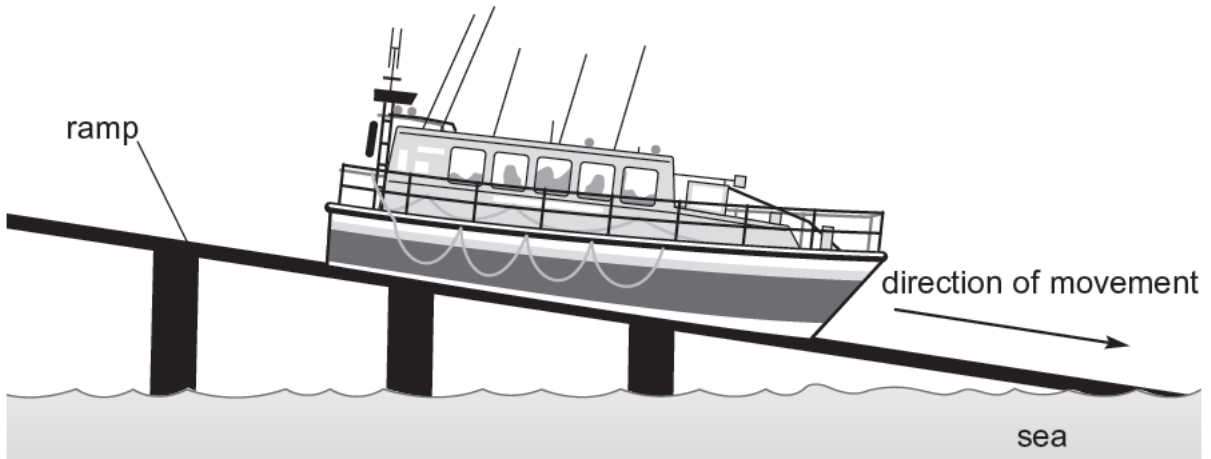

Use words from the box to complete the sentences below.
You can use words more than once.

chemical	electrical	gravitational potential	
light	sound	thermal	kinetic

(i) As the lifeboat slides down the ramp, the **useful** energy transfer is from _____ energy to _____ energy.

(ii) The lifeboat engine burns fuel.
The _____ energy in the fuel is transferred into useful _____ energy.

ai
1 mark

ai
1 mark

all
1 mark

all
1 mark

(b) Akash saw a rocket flare explode in the distance.

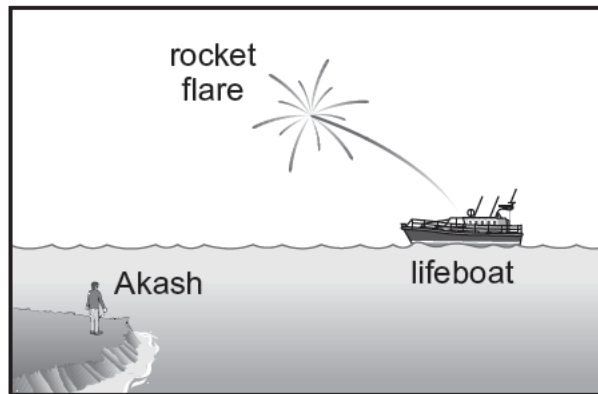

(i) The rocket flare produced a bright light and a loud bang at the same time. Why did Akash see the light before he heard the bang?

bi
1 mark

(ii) The diagram below shows the rocket flare falling. All the fuel in the rocket has been used.

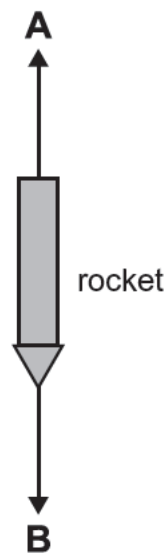

Two forces act on the falling rocket. Give the name of the two forces, A and B.

A _____

B _____

bi
1 mark

bi
1 mark

maximum 7 marks

5. Robert was hanging some wet clothes on a washing line.

He thought:



(a) Describe how you could test Robert's idea.

a

1 mark

a

1 mark

(b) There are other variables that affect how long the washing takes to dry outside.

Suggest **two** other variables that will affect how long washing takes to dry outside.

1. _____

2. _____

b

1 mark

b

1 mark

(c) When washing dries, what happens to the water in the clothes?

c

1 mark

- (d) The diagram below shows particles in a gas, a solid and a liquid. Each arrow, A, B, C and D, represents a change of state.

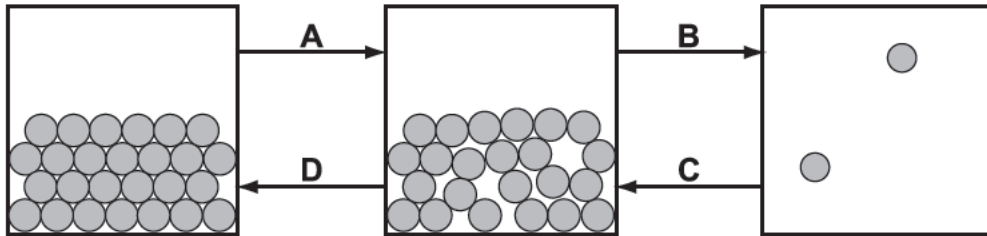

- (i) In the diagram above, which change of state takes place as clothes dry?
Tick the correct box.

A B C D

di
1 mark

- (ii) Which changes of state involve thermal energy being **added**?
Tick the correct box.

A and B B and C
C and D D and A

dii
1 mark

maximum 7 marks

6. (a) Asha put four compasses around a bar magnet as shown below.

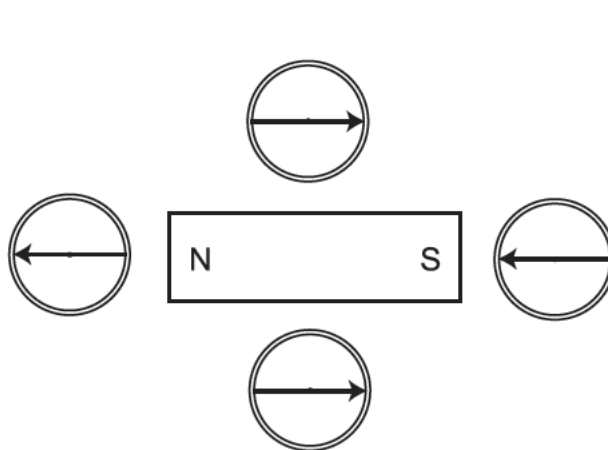

Asha placed the same compasses around a coil of wire. A current flowed through the coil.

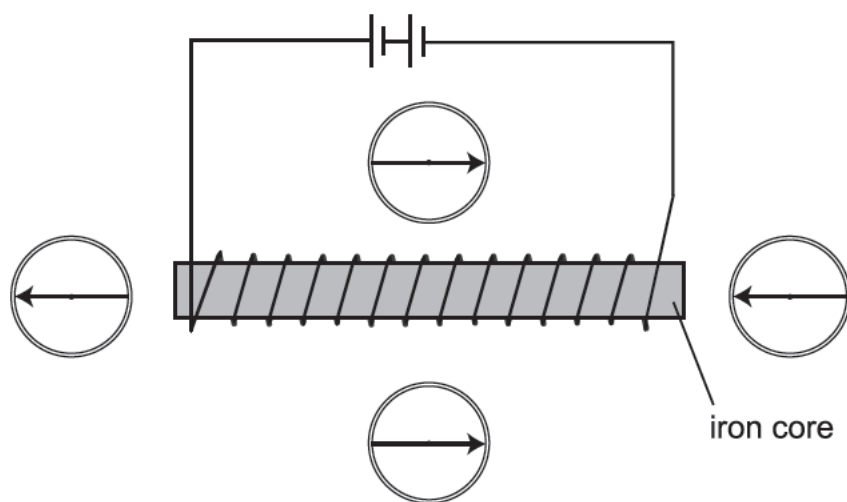

(i) How can you tell that the magnetic field around the coil is the same as the field around the bar magnet?

ai

1 mark

Asha reversed the direction of the current in the coil.

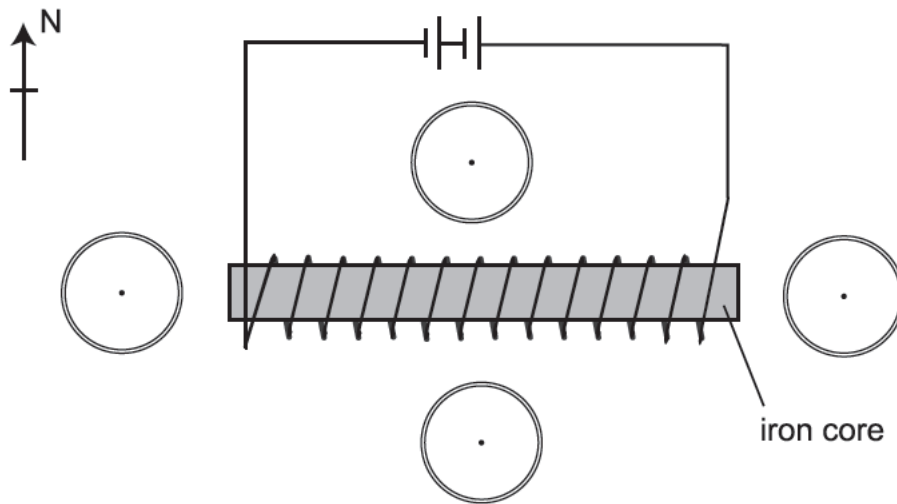

all
1 mark

(ii) Draw an arrow in each of the circles above to show the direction the compasses would point.

(iii) How did Asha reverse the direction of the current in the coil?

all
1 mark

(b) Asha replaced the iron core with a piece of wood. Draw an arrow in each of the circles below to show the direction the compasses would point.

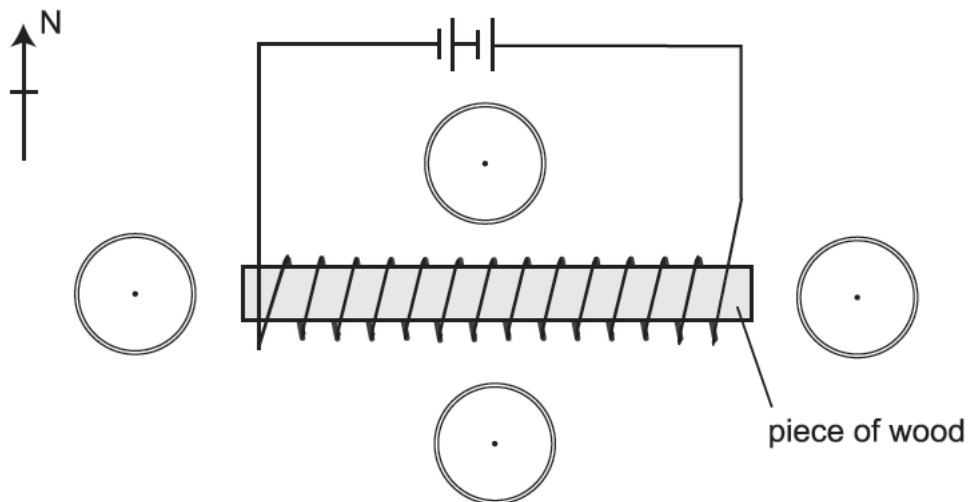

b
1 mark

maximum 4 marks

7. At the moment, if scientists want to put something into space, they use a large rocket. Rockets burn a large amount of fuel.

Engineers suggest there may be a better way to get objects into space – by building a space lift.

The diagram shows what the space lift may look like.

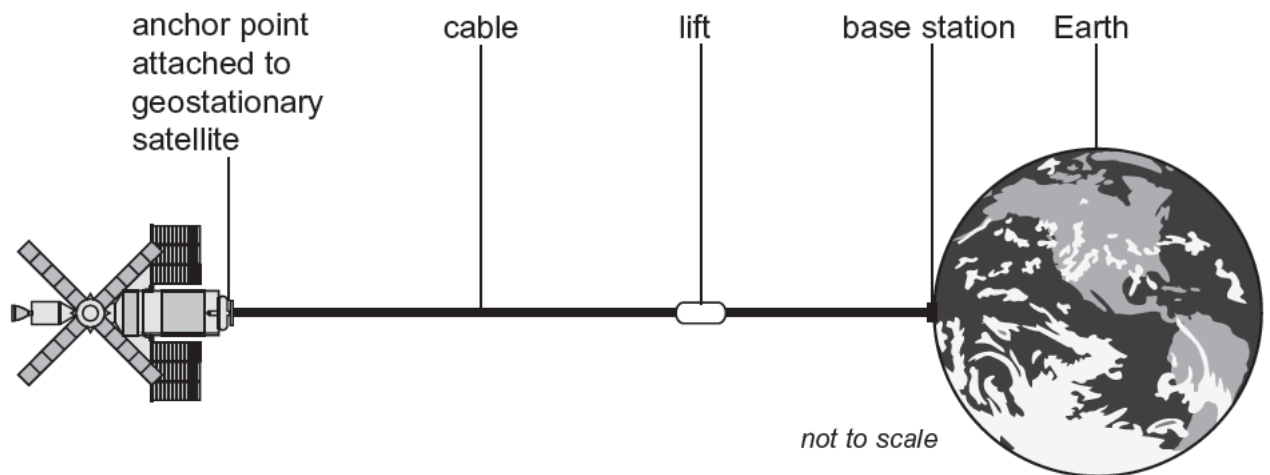

- (a) Suggest **one** possible advantage of using a space lift rather than a rocket to get things into space.

- (b) The space lift would be attached to an artificial satellite in space called a *geostationary* satellite. It is called a geostationary satellite because it always stays above the same spot on the Earth.

- (i) How long would it take for a geostationary satellite to complete one full orbit of the Earth?

- (ii) Give **two** current uses of artificial satellites.

1. _____

2. _____

a
1 mark

bi
1 mark

bii
1 mark

bii
1 mark

- (c) It will be expensive to build the space lift and it requires very strong materials for the cable.

Some people believe that the cable should be made from *carbon nanotubes*. Carbon nanotubes are long molecules made from carbon atoms. These carbon atoms are joined together to make them very strong.

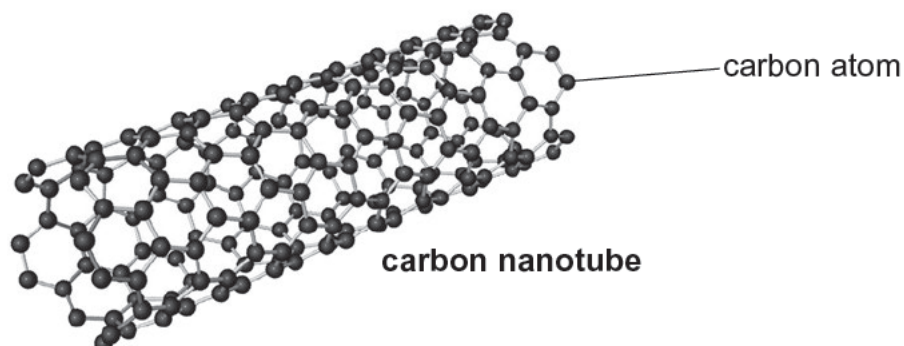

Carbon nanotubes could be put together one atom at a time by very small machines called *nanomachines*.

Nanomachines are tiny machines the same size as molecules. One kind of nanomachine could be used to separate carbon from carbon dioxide in the atmosphere.

Complete the **word** and balanced **symbol** equations below to show the reaction that occurs in these nanomachines.

word: carbon dioxide \longrightarrow carbon + _____

symbol: _____ \longrightarrow _____ + _____

- (d) To build the space lift, scientists from different countries will have to work together.

(i) Give **one** benefit of countries working together to build the space lift.

(ii) Give **one** possible problem of countries working together.

 c

1 mark

 c

1 mark

 di

1 mark

 dii

1 mark

maximum 8 marks

8. Corals are tiny animals. They are found in shallow water. The coral produces calcium carbonate, which forms a hard outer skeleton. The skeleton is attached to rock or other coral.

coral outer skeleton

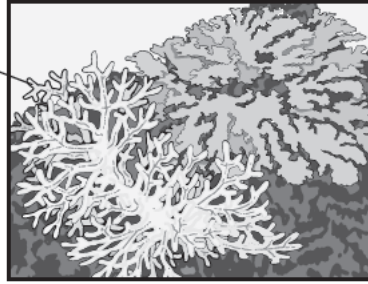

- (a) The outer skeleton is a useful adaptation for corals. What does the outer skeleton protect the coral from?

- (b) Corals need green plants to survive. Explain why these green plants are only found in **shallow** water.

- (c) Coral islands are often found in the middle of deep oceans.

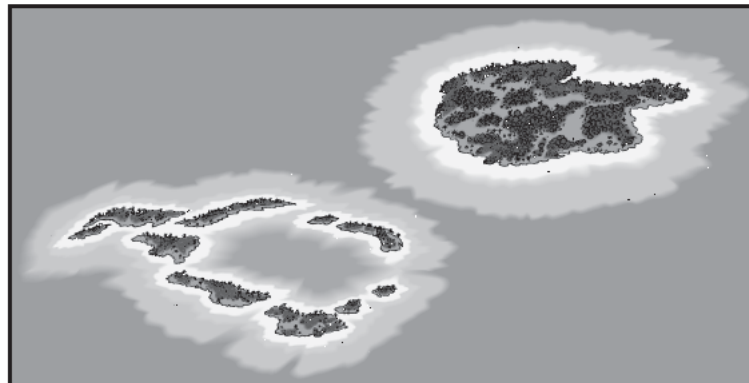

The scientist Charles Darwin was interested in how coral islands formed. He suggested that:

- the coral grows in the shallow water around a volcano
- over millions of years the volcano sinks under the water
- the coral grows on top of earlier coral as the volcano sinks.

Scientists today think Darwin's ideas are correct.

a
1 mark

b
1 mark

b
1 mark

- (i) The diagrams below show cross-sections through an island at different times. Write the **numbers 1 to 3** to show the order in which the coral island forms.

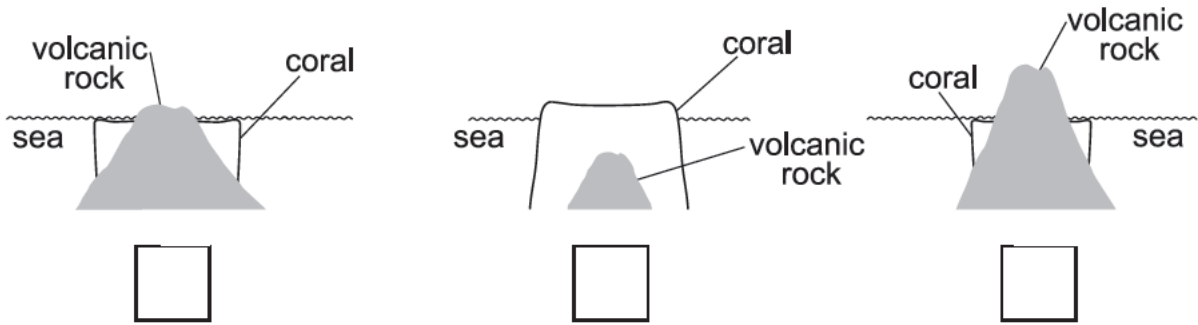

cl
1 mark

- (ii) Use the information above and opposite to suggest why coral islands are in the form of rings.

cil
1 mark

- (d) Charles Darwin predicted that evidence could be found to support his theory about islands. To find evidence the scientists would need to drill down through a coral island to investigate the rocks underneath.

Which type of rock would they need to find to support Darwin's theory?

Tick the correct box.

igneous metamorphic sedimentary

Explain why.

d
1 mark

maximum 6 marks

9. Diamond and graphite are both made of pure carbon. The graph below shows the physical states of diamond and graphite at different temperatures and pressures.

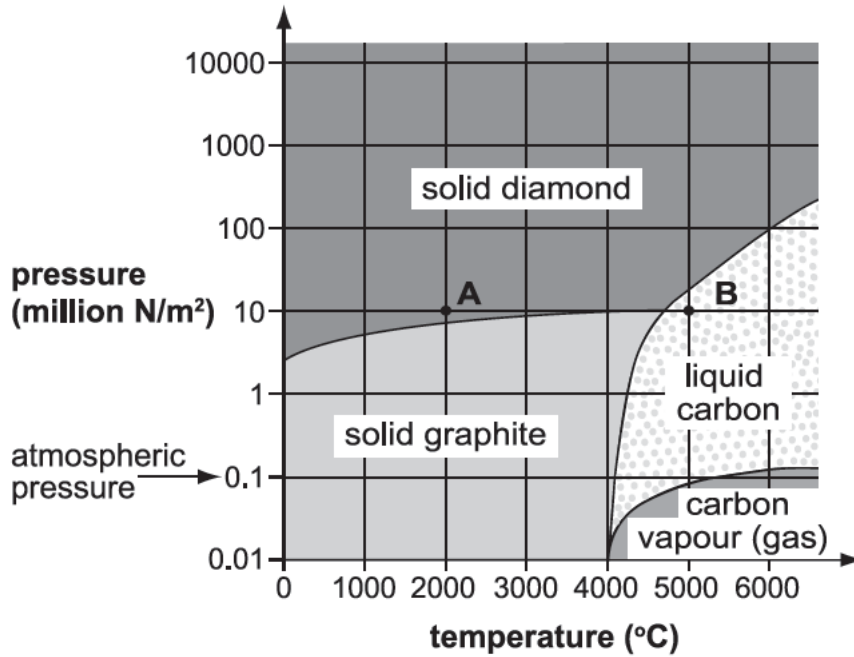

- (a) At which temperature and pressure is carbon a liquid?
Use the graph to help you. Tick the correct row in the table below.

temperature (°C)	pressure (million N/m ²)	liquid?
1000	10	
3000	10000	
5000	0.1	
6000	0.01	

a

1 mark

- (b) Point **A** on the graph shows solid diamond at 2000°C. Solid diamond is heated at a constant pressure of 10 million N/m² to a temperature of 5000°C (point **B**).

- (i) At what temperature does diamond melt at this pressure?

_____ °C

bi

1 mark

- (ii) What happens to the melting point of diamond as the pressure increases?

bii

1 mark

- (c) Use the graph to describe what happens to solid graphite when it is heated to 5000°C at atmospheric pressure.

c
1 mark

- (d) Use the graph. What pressure do you need to change liquid carbon to solid diamond at 6000°C?

_____ million N/m²

d
1 mark

- (e) Diamonds are formed **deep** underground, where the pressure is high. What causes high pressure deep underground?

e
1 mark

- (f) The diagram below shows how small diamonds are made in a laboratory.

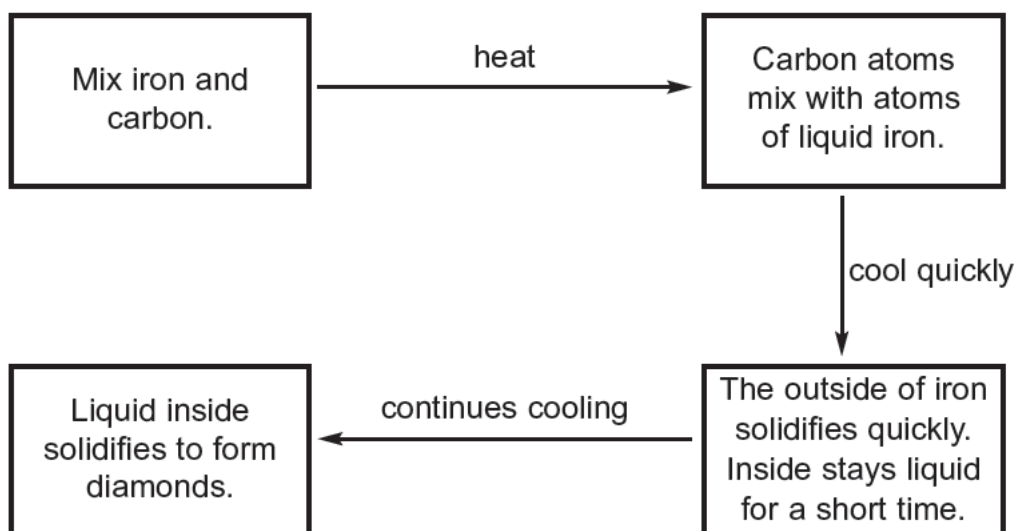

Diamonds made by this method are smaller than diamonds found underground. Suggest why diamonds found underground are larger.

f
1 mark

Please turn over for part (g).

-
- (g) Iron **expands** when it turns from liquid to solid.
Would solid iron float or sink in liquid iron?
Tick **one** box.

float sink

Explain your answer.

g
1 mark

maximum 8 marks

Total

8

Please turn over for question 10.

10. The diagrams show two groups of animal cells from the small intestine.

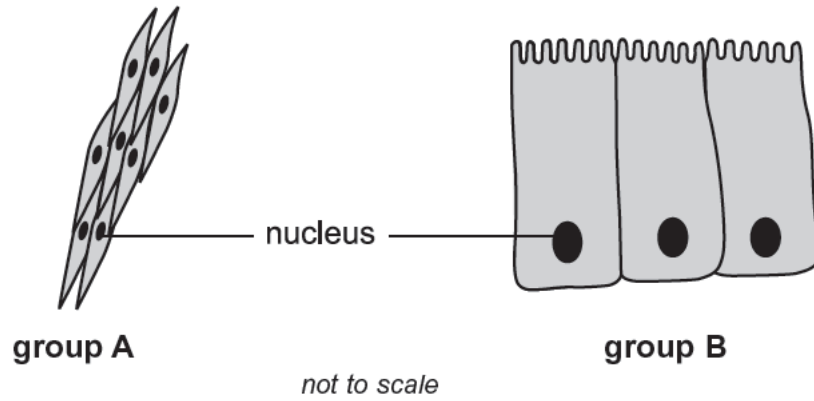

(a) What is the function of the nucleus?

a
1 mark

(b) (i) The cells in group A are muscle cells in the wall of the small intestine. Muscle cells can contract.

Give one reason why muscles are needed in the intestine.

bi
1 mark

(ii) Enzymes are produced by cells in the small intestine. What effect do enzymes have on food?

bii
1 mark

The cells in group B absorb food molecules in the small intestine and pass them into the bloodstream.

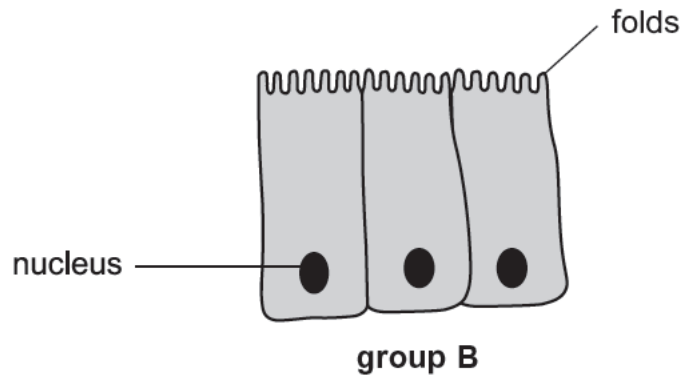

(iii) How are the cells in group B suited to their function?

biii
1 mark

END OF TEST

maximum 4 marks

